

Teleskopski klizač, H45, PRESTIGE

L = 250 - 300 - 350 - 400 - 450 - 500 - 550 - 600 - 700 mm

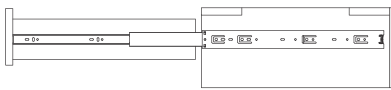

DK - dužina klizača

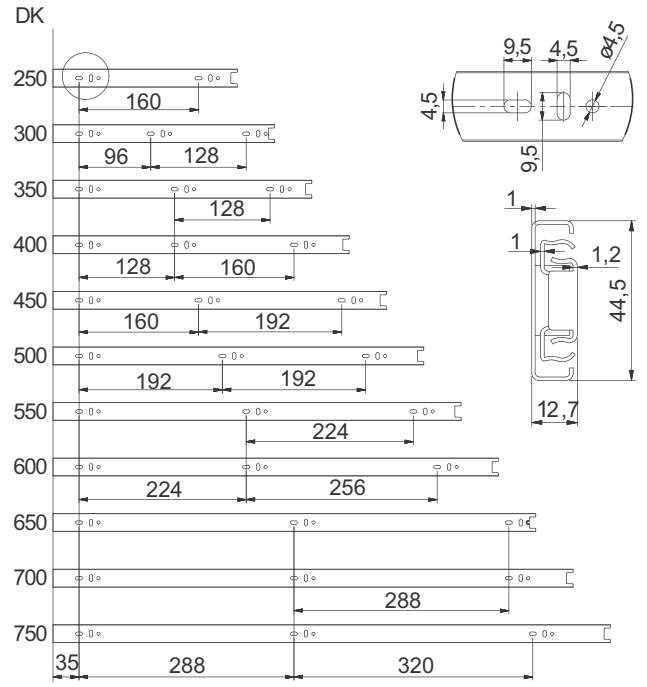
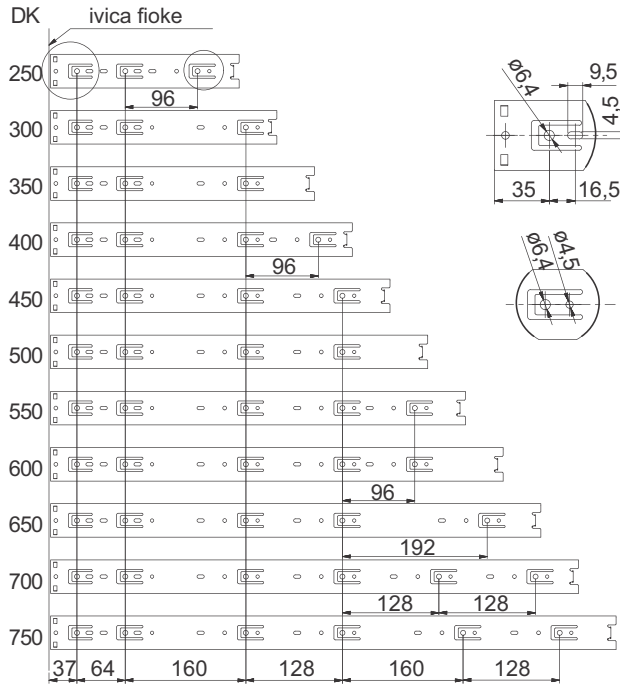
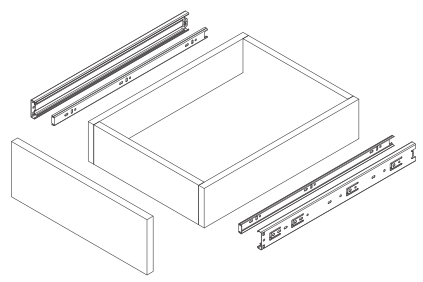

* Za pravilan rad klizača, širina fioke ne bi smela da prelazi dužinu klizača!

Širina fioke

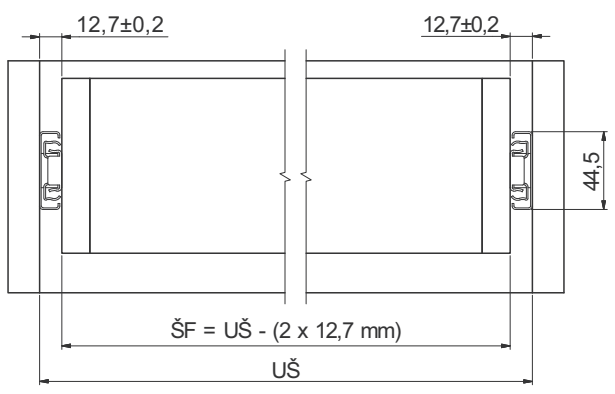

UŠ = unutrašnja širina korpusa
ŠF = širina fioke

Standardna fioka

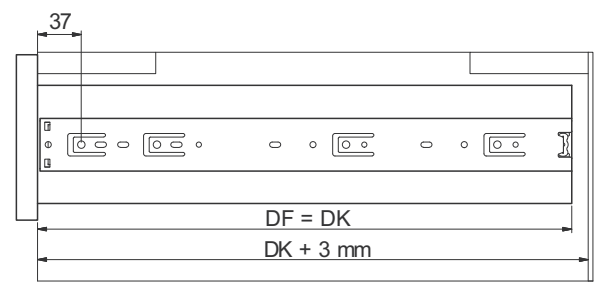

Unutrašnja fioka

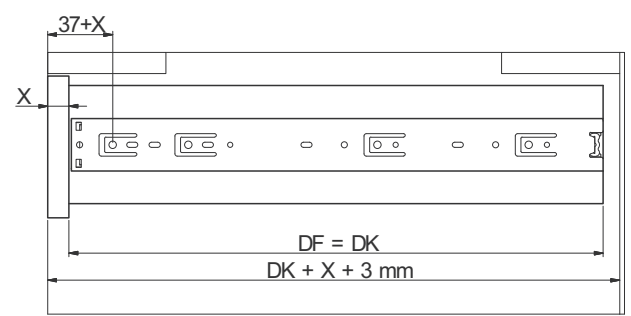

X = debljina fronta fioke DF = dubina fioke
DK = dužina klizača