

Teleskopski klizač, H45, Ekonomik
L = 250, 300, 350, 400, 450, 500, 550, 600, 700 mm

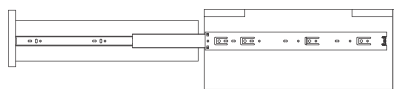

DK - dužina klizača

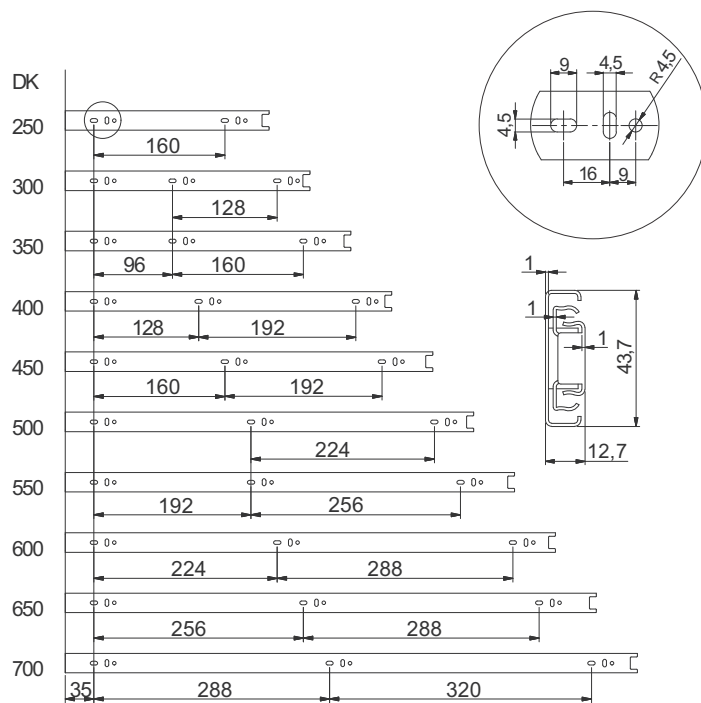
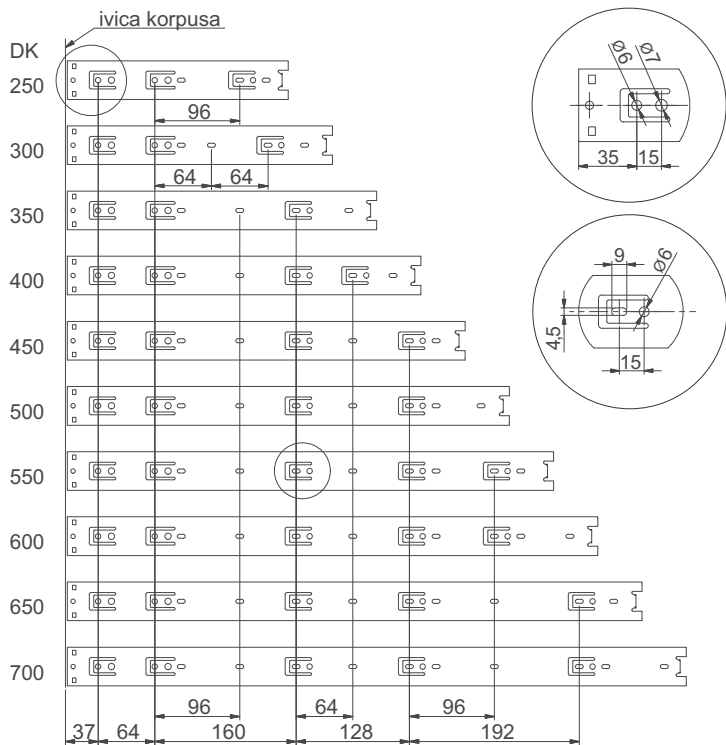
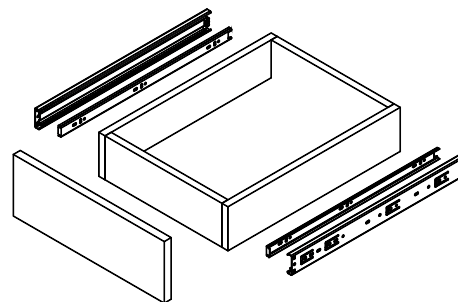

* Za pravilan rad klizača, širina fioke ne bi smela da prelazi dužinu klizača!

Širina fioke

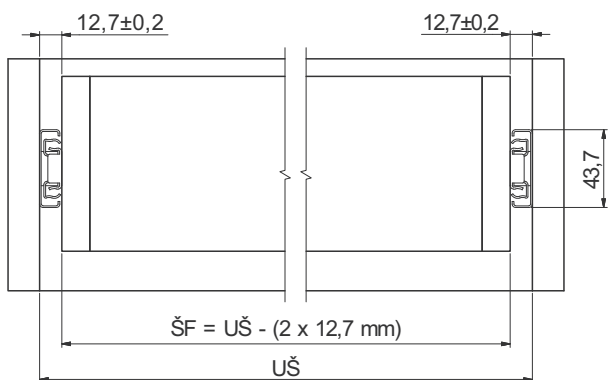

UŠ = unutrašnja širina korpusa
ŠF = širina fioke

Standardna fioka

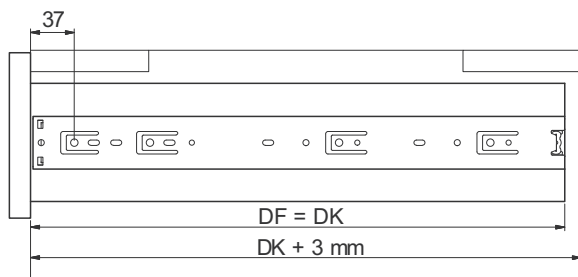

Unutrašnja fioka

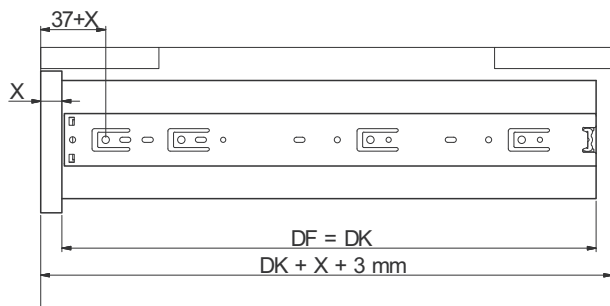

X = debljina fronta fioke DF = dubina fioke
DK = dužina klizača